

RCEL005 / RCEL006-250

High quality electric actuators

REMOTE CONTROL has been manufacturing actuators since 1961



RCEL005

RCEL006-250

RCEL – series meet all International Standards for easy and quick mounting of actuators on valves.

The RCEL Actuator has a smooth and easy operation which considerably increases the life expectancy of the valve.

The technical advantages of the electrical actuators produced by Remote Control are much appreciated by our customers.

“Power Start”

The RCEL-series has an unique rising of the rpm prior to start which results in a higher starting torque. This is necessary when valves have been sitting idle for a long time and initially need more force to be manoeuvred.

RCEL006-250 is also available with extended rotation angle and in explosion-safe design.

Accessories such as local control units or digital regulation cards and positioners can easily be installed.

Technical Data

- For On – Off regulation
- Torque range: 50 Nm – 2,452 Nm.
443 lbf.in – 21,702 lbf.in
- Mounting kits for all 90° valves.
RCEL006-250 also for 120°, 135°, 180°, 270°, 300°.
- Connections and hole constellations in compliance with International standard: ISO5211 (DIN 3337) and DIN 79.
- Permanently lubricated and self locking gear drive.
- Temp: RCEL005: -20 ° to +70 °C
RCEL006-250: -30 ° to +70 °C
- Feed Voltage:
RCEL005: 24 VDC (Option 24 VAC).
110 / 230 VAC, 1-phase

RCEL006-250: 24 VDC (Option 24 VAC).
110 / 230 VAC, 1-phase.
380/400/440 VAC, 3-phase.
- Safety Class:
RCEL005: IP 68.
RCEL006-250: IP 67 (Option 68)
- CE labelled.
Approval CSA - UL.
ATEX (Option).
- Manual Override in case of power failure.
- Smooth running.
- Compact proportions.
- Built-in heater preventing condensation.
- Housing made from centrifugally cast anodized and epoxy painted aluminium.
- Long life, maximum dependability.

RCEL005 - Compact - Adaptable - 50 Nm

Limit Switches

2 potential-free Switches
2 limit-position Switches

Indicator

Illuminated indicator for visual indication of end position

Motor

Fully enclosed
Quiet operation
Thermal motor protection

Connection

Vibration-safe plinths
No special tools needed

Screws

External screws stainless steel

Space Heater

Prevents condensation

Self-locking gears

Mechanical breaks not needed
Permanently lubricated

Cable input

M20 x 1,5

Highest Surface Finish

Centrifugally cast aluminium
Externally and internally anodized
Dry Powder Epoxy painted

Emergency Operation

Manually with 6 mm hex key.

Mounting Flange

ISO 5211 (DIN 3337)
F03 - F05 - F07



High casing on RCEL 005 L

To facilitate mounting of accessories



Rotation axle

Complies with International standard for square spindles, ISO 5211 and DIN 79, 14 mm

RCEL006-250 - The strong choice - Up to 2,450 Nm - Even EEx

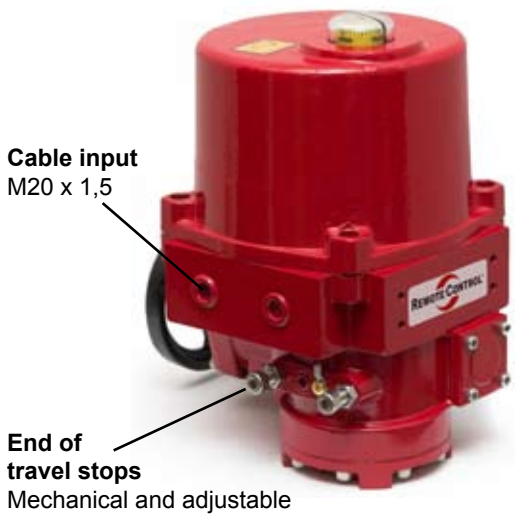
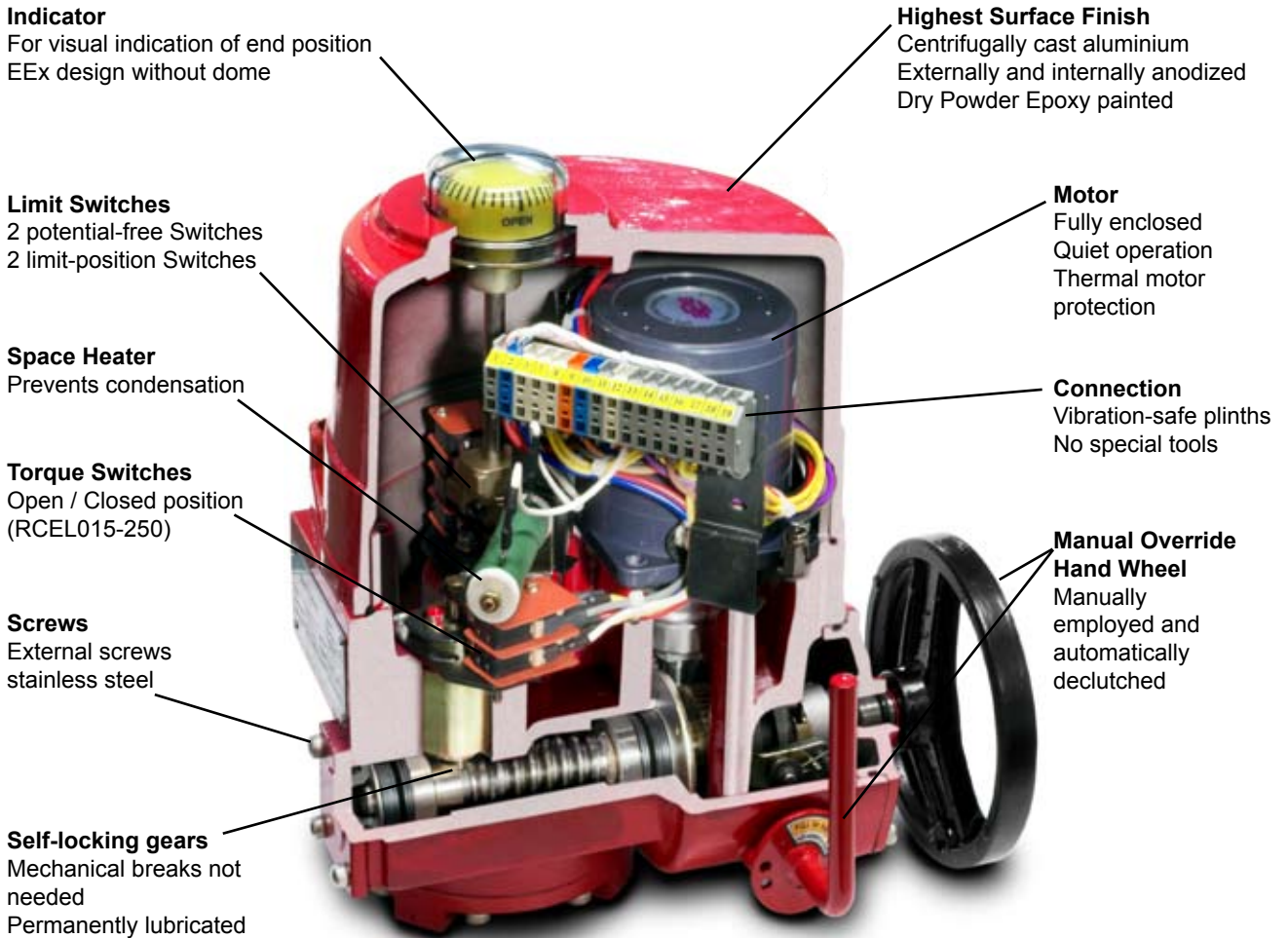

Puller
Easy dismantling of the driving
bush by use of existing screws,
no puller needed.

**Individualized Mounting
Angle**
For each 45°
8 screws

Mounting Flange
ISO 5211 (DIN 3337)
F07, F10, F12, F14, F16

Driving Bush enclosed
Delivered unfinished (without holes, for your own adaptation)
or adapted to International standard for square spindles, DIN 79,
Standard from 22 to 75.
Can be adapted according to customer specification.

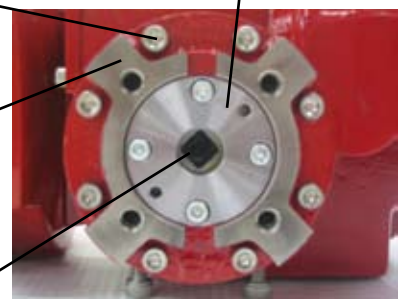

Dimensions RCEL005 - 005L

Type	Torque Nm	Flange ISO 5211	D Max Ø mm	Std hole / axle mm	Total height mm	Total width mm	Total depth mm
005	50	F03-05-07		∅14	148	168	132
005L	50	F03-05-07		∅14	208	168	132

RCEL005

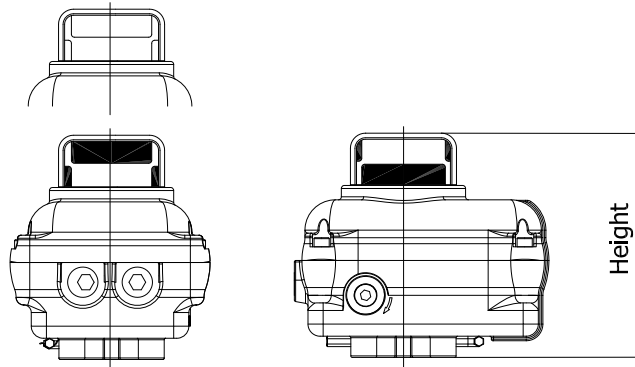

007363

RCEL005L

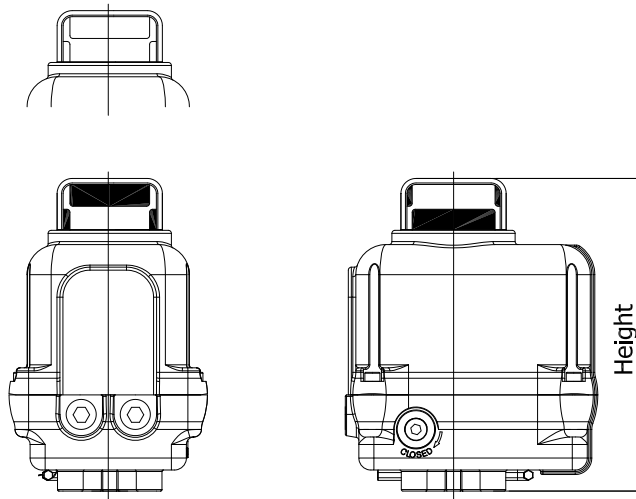

007364

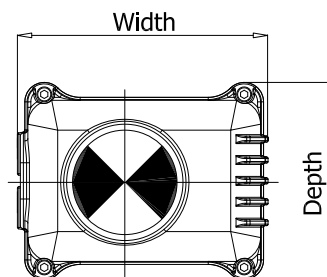

Dimensions RCEL006 - 250

Type	Torque Nm	Flange ISO 5211	D Max Ø mm	Std hole / axle mm	Total height mm	Total width mm	Total depth mm
RCEL 006	58	F07	22	□ 17	273	231	181
RCEL 009	88	F07	22	□ 17	273	231	181
RCEL 015	147	F07-F10	22	□ 17	273	261	224
RCEL 019	186	F07-F10	22	□ 17	273	261	224
RCEL 028	274	F10-F12	32	□ 22	320	285	258
RCEL 038	373	F10-F12	32	□ 22	320	285	258
RCEL 050	490	F10-F12	32	□ 22	320	285	258
RCEL 060	588	F12-F14	42	□ 27	361	325	307
RCEL 080	785	F12-F14	42	□ 27	361	325	307
RCEL 100	981	F12-F14	42	□ 27	361	325	307
RCEL 150	1471	F14-F16	75	□ 36	556	388	318
RCEL 200	1962	F14-F16	75	□ 36	556	388	318
RCEL 250	2452	F14-F16	75	□ 36	556	388	318

RCEL006-100

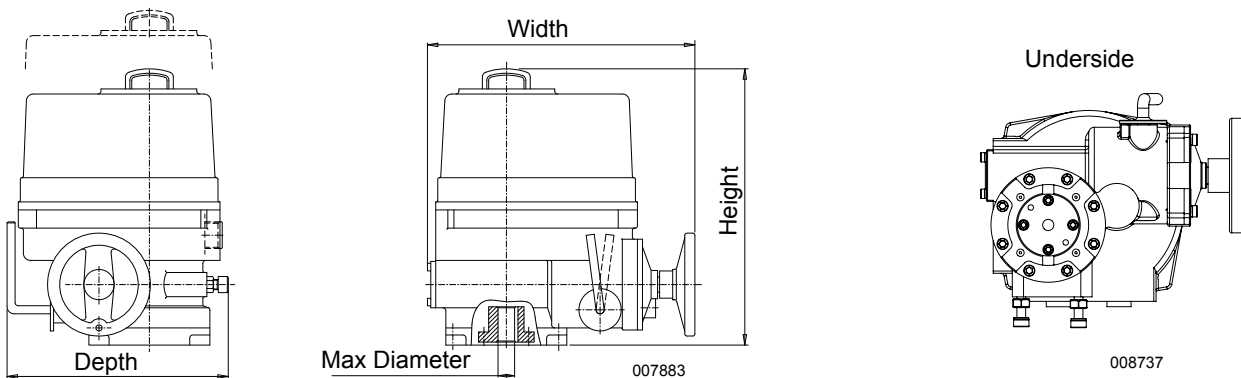

RCEL150-250

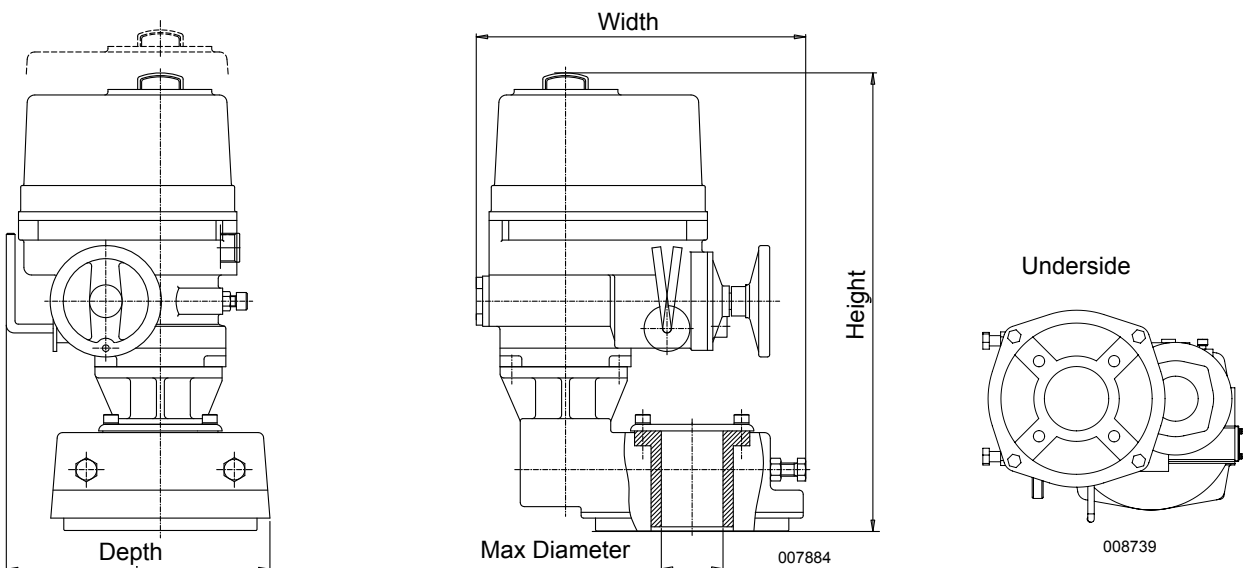

Accessories

Adaptation of driving bush

A driving bush is delivered as a standard with all actuators, for customer's own adaptation or adapted as below.

- RCEL 005-005L: 14mm, ISO 5211 and DIN 79.
- RCEL 006-019: 22mm, DIN 79
- RCEL 028-050: 32mm, DIN 79
- RCEL 060-100: 42mm, DIN 79
- RCEL 150-250: 75mm, DIN 79

Remote Control has blueprints of more than 6,000 different valves for manufacturing valve adaption kits. Remote Control also offers adapted driving bushes according to customer requirements.



Mounting kit, console and driving bush

When direct mounting is not possible.

Standard design according to ISO 5211 and DIN 3337. Measurements F07, F10, F12, F14, F16.

Individually adapted to valves according to customer specifications.



Mounting actuator on valve.

Remote Control offers mounting of the actuator onto the valve. The complete unit is calibrated and test run prior to delivery



PIU. Potentiometer kit

For modulating actuators. Continually monitors the actuator position throughout the full rotation motion. PIU is built into the actuator at factory. Can also be mounted later.

Available to RCEL005L and RCEL006-250 and EEx-Actuators. Mounting details are enclosed.



Operating panel

Customized control panel.



Accessories

CPT. Continuous Position Transmitter

For externally controlled actuators.

4 – 20 mA, 0 – 1 kΩ, R/I converter. Safety class IP 67.

RCEL 005L: To be ordered as a complete unit.

RCEL 006-009: CPT built into the PCU housing.

RCEL 015-250: CPT built into the actuator.

Not for EEx – actuators.



PCU PB90. Position Control Unit for RCEL 006 - 250

4 – 20 mA or 0 – 10 V input signal; split range

Return signal 4 – 20 mA, max load 300Ω.

Safety Class IP 67.

For 3-phase 380/500V:

RCEL 006-019: PCU PB90 built into the PCU housing

RCEL 028-250: PCU PB90 built into the actuator.

For 24VDC:

RCEL 006-019: PCU PB90 build into the PCU housing.

RCEL 028: PCU PB90 build into the actuator

Not for EEx – actuators.



LCU1. Local Control Unit for RCEL 006 – 250.

Lockable 3-position handle for choice of local control.

Open – Stop – Close.

The handle is mounted in a separate housing.

Safety Class IP65.

RCEL 005L: To be ordered as a complete Unit.

LCU1 can be delivered for wall mount.

Not for EEx – actuators.



LCU2. Local Control Unit for RCEL 006 – 250.

2- and 3-position handle for choice of remote or local control.

The handle is mounted in a separate, lockable housing made from transparent polycarbonate.

LED indication.

230 VAC

380 VAC

Safety Class IP 66.

LCU2 can be delivered for wall mounting.

Not for EEx - actuators



Accessories

PCU DHC-100D. Digital modulating card / High performance Positioning Kit.

Resolution: 450 points per 90° movement.

Is mounted in the actuator at delivery if requested, can also easily be mounted later.

Input signal: 4 – 20 mA, 0 - 5V, 1 – 5V and 0 – 10V.

Easily calibrated with buttons on the front panel.

Simple configuring of all parameters.

Optional rotation direction.

Adaptable control function continually modulating the load of the electric actuator.

Safety function for overloading (detection).

Faulty signal indicated by flashing LED.

Eliminates overload through operation-time protection.

Programmable function wrong input signal open, stop or close.

Can be combined with transmitter type OTX-100 or OTR-100 for return signal 4 – 20 mA.

For 1-phase 230 V, not for EEx-Actuators or actuator RCEL 005 with low cover.



OTX-100. Transmitter for return signal.

Return signal: 4-20 mA.

Simple installation. Plugged directly into PCU DHC-100D.

Eliminates extra wiring. Easily calibrated with buttons on the PCU DHC-100D.

Voltage or current output can be adjusted to optional range within 0 – 10 V DC with steps of 0,0016 V or within 0 – 20 mA with steps of 0,0031 mA.

OTX-100 can be mounted at a later point in time.

For 1-phase 230 V, not for EEx- actuators.



OTR-100. Transmitter for return signal and faulty information.

Return signal 4 – 20 mA.

Simple installation. Plugged directly into PCU DHC-100D.

Eliminates extra wiring. Easily calibrated with buttons on the PCU DHC-100D.

Voltage or current output can be adjusted to optional range within 0 – 10 V DC with steps of 0,0016 V or within 0 – 20 mA with steps of 0,0031 mA.

Relay outputs, 2 pcs programmable + 1 pc for faulty function alarm
OTR-100 can be mounted at a later point in time.

For 1-phase 230 V, not for EEx – actuators.



AMM-100. Manual Override Module.

Makes it possible to combine Local Control Unit type LCU1 with Position Control Unit PCU DHC 100D.

Simple installation. 2-thread communication.

Can be combined with push buttons or handle.

AMM-100 can be mounted at a later point in time.

For 1-phase 230 V, not for EEx –actuators.



Advantages with RCEL actuators

- Strength:** “Power Start” delivers higher torque during the start.
Consultation worldwide.
Technical support from specialists, and direct customer support.
Service / spare parts from factory.
Training in the factory or at the customer’s location.
- Safety:** CE labelled.
Approval CSA –UL.
ATEX (option). RCEL006-250.
Self locking gear.
Manual override wheel in case of power loss. (RCEL006-250)
Allen key for manual operation. (RCEL005-005L)
4 Limit Switches as standard, of which 2 pcs are potential free.
Thermal motor protection. (Not for 24VDC).
Mechanical end of travel stops.
Vibration-safe plinths.
- Delivery:** Fast deliveries from warehouse in Falun, Sweden.
Delivery inspection of all Actuators.
Unattached Actuators have basic settings at delivery.
Actuators mounted on valves are calibrated before delivery.
- Warranty:** 1 year warranty
- Mounting:** Compact dimensions on the Actuators.
Remote Control has blueprints for the manufacturing of more than 6000 different valve adaption kits.
Customer adapted special applications.
Mounting Kits: International standard ISO 5211, DIN 79 and DIN 3337.
- Material Quality:** Centrifugally cast aluminium.
Exterior and interior anodized.
Dry powder painted.
Fully enclosed, low noise motor.
Built-in heater preventing condensation.
Stainless steel.

QUALITY - RELIABILITY - STRENGTH

Quality

Remote Control is certified according to ISO 9001 and ISO 14001.

All Remote Control electric actuators are manufactured under rigorous quality control.

The RCEL Actuators comply with all International standard demands. All products are CE-labelled and manufactured according to EMC and the ATEX-directive.

The recognized high quality of RCEL's Actuators safeguards Actuators of Highest Class to our customers.

Reliability

The design is simple and robust. We only use material of the highest quality in manufacturing, which results in Actuators with high life expectancy.

Strength

RCEL Actuators are strong and unique. The secret lies in the "Power Start" which gives an increased torque during the start-up mode, exactly when the valve needs the most force.



Richard Lang.
Managing Director.
RWL, Austria.

"As a distributor of Remote Control I have sold their products in many parts of Europe for a number of years.

I myself and my customers appreciate the **quality**, the **prompt deliveries** and the **good service**.

On several occasions I have visited Remote Control in Falun, Sweden, accompanied by customers for special training.

We have appreciated finding a business that both make sure the customer gets the best product on the market and, at the same time, the employees have a safe and pleasant workplace".

Packing & Delivery

Remote Control quality system ISO 9001 also encompass packing and delivery.





CE-marking according to the Pressure Equipment Directive PED 97/23/EC



Environment Control ISO 14001:2004



Quality Assurance ISO 9001:2000

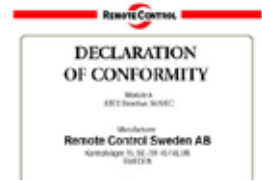

CE-Marking according to ATEX Directive 94/9/EC



RCEL 005
 Electric actuator
 50 Nm
 mounted on valve



RCEL 006-250
 Electric actuator
 58 Nm to 2,450 Nm
 mounted on valve



RCE-SR
 Electric actuator
 with spring return
 mounted on valve



Remote Control Sweden AB
 P O Box 80, Kontrollvägen 15
 SE-791 22 Falun
 Sweden

Tel +46 (0)23 587 00
 Fax +46 (0)23 587 45
 info@remotecontrol.se

www.remotecontrol.se

We reserve the right to make changes without notice

Ref No: 787 / ArtNo:980787